



education

Department:
Education
REPUBLIC OF SOUTH AFRICA

**NATIONAL
SENIOR CERTIFICATE**

GRADE 12

AGRICULTURAL TECHNOLOGY

NOVEMBER 2008

MEMORANDUM

MARKS: 200

This memorandum consists of 11 pages.

SECTION A

QUESTION 1

- 1.1 C✓✓✓
- 1.2 B✓✓✓
- 1.3 A✓✓✓
- 1.4 C✓✓✓
- 1.5 C✓✓✓
- 1.6 A✓✓✓
- 1.7 B✓✓✓
- 1.8 C✓✓✓
- 1.9 C✓✓✓
- 1.10 C✓✓✓
- 1.11 C✓✓✓
- 1.12 B✓✓✓
- 1.13 A✓✓✓
- 1.14 B✓✓✓
- 1.15 B✓✓✓

[45]

TOTAL SECTION A (15 x 3): 45

SECTION B**QUESTION 2: MATERIALS AND STRUCTURES**

- 2.1 2.1.1 To prevent the sheets from rusting. (Corrosion) (oxidation) (protection)✓ (1)
- 2.1.2 Mild steel sheets are cleaned with hydrochloric acid, ✓ then fluxed with zinc-chloride ✓ and dipped into molten tin. ✓ (3)
- 2.1.3
- In food processing (tinned food, cans) ✓
 - For trays ✓
- Cups and mugs
Tinned plates (any two) (2)
- 2.1.4 The process is called oxidation. ✓
Oxidation is the slow process of metal deterioration. ✓This process takes place when pure metals✓ are exposed to oxygen ✓ and water. ✓ (5)
- 2.1.5
- Electroplating ✓
 - Painting ✓
 - Galvanising (any two) (2)
- Chroming
Polishing
- 2.2 2.2.1 Concrete starts setting after 1hour, ✓and must not be re-mixed after that period. The concrete will loose its strength , ✓ because the chemical bonding process was stopped. ✓ (3)
- 2.2.2
- Make sure of the size/measurements of the foundation. ✓
 - The mixture of the cement in the foundation. ✓
 - Drainage of excess water away from the structure.✓
- Reinforcement . (Wider and thicker.) (any three) (3)
- 2.3 2.3.1 Carry stress/load of roof. ✓ (1)
- 2.3.2 (2) Knock✓
(3) Struts✓
(5) Beam✓ (3)
- 2.3.3 Triangles because of their specific shape/design are very strong. ✓
It strengthens the construction so that the struts can carry the weight of the roof. ✓ (2)

2.4

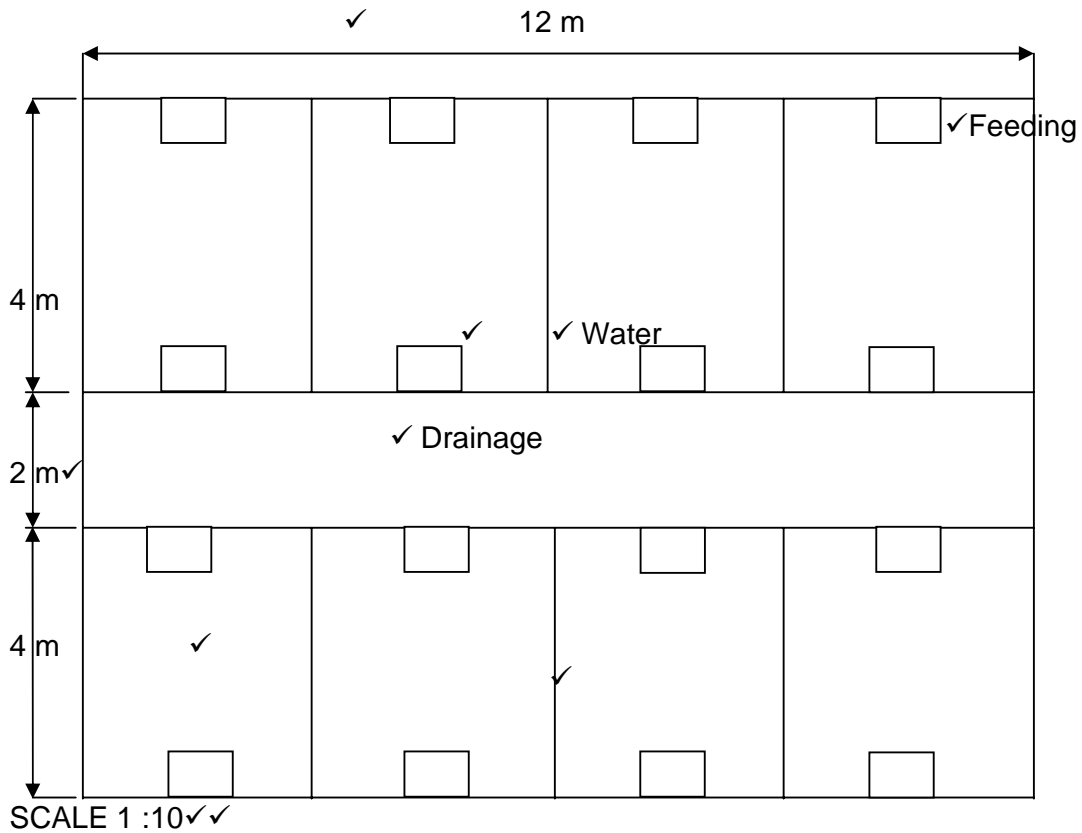

(10)
[35]

To the marker

This is the technical process that has been followed and it will differ according to individual learners and their own experience and pre-knowledge.

Identify the criteria during the marking process.

Award the marks according to the criteria.

QUESTION 3: ENERGY

- 3.1 3.1.1 Solar energy/Sun energy ✓/light (1)
- 3.1.2 Inverter/transformer. ✓(converter) (1)
- 3.1.3 Yes. ✓
The electric energy produced during daytime ✓ can be used to charge a battery that can be used during night time. ✓ (3)
- 3.1.4
- Sunlight is free. ✓
 - Pollution free. ✓
 - Low maintenance cost
 - Can be used in remote areas where no electricity is available.
- (any two) (2)
- 3.1.5
- Sun energy is not available during the night time. ✓
 - A cloudy day makes this energy source ineffective. ✓
 - Produce low amounts of energy at low voltage and amperage. ✓
 - High installation cost.
- (any three) (3)
- 3.1.6
- Follow the manufacturer's specifications. ✓
 - Adhere to national safety standards. ✓
- (2)
- 3.2 3.2.1 Battery/Accumulator. ✓ (1)
- 3.2.2
- A Battery/Accumulator ✓
 - B Ignition switch ✓(key, ignition key, starter switch)
 - C Ignition coil ✓
 - D Distributor ✓
 - E High tension leads/Sparkplug wires/Secondary conductors ✓
- (5)
- 3.2.3 Ignition coil. /C ✓ (1)
- 3.2.4 Negatively. ✓ (1)
- [20]**

QUESTION 4: SKILLS AND CONSTRUCTION PROCESSES

- 4.1 4.1.1
- Make sure that all rust, grease, dirt and/or any other substances, which can weaken the joint has been removed, before starting with the process of joining. ✓
 - Remove the surface layer of the metal where the joint is to be made. ✓
 - Cover the suspect area with white chalk. Vaseline in the cracks will colour the chalk grey or show a wet line. ✓
 - Mark the line by means of a prick-punch and hammer to prevent the line from disappearing when grinding out the V-groove. ✓
 - Arc must be a little longer than when welding mild steel. ✓
 - Use a pure nickel-welding rod. ✓
 - Amperage must be as low as possible. ✓
 - It is very important that the casting is kept as cool as possible during the welding process. ✓
 - Casting should be allowed to cool down slowly after welding. ✓
 - Pre-heating of a casing to be welded can help to prevent it from forming new cracks. ✓
- (10)
- 4.1.2 It will crack, ✓ because of uneven cooling. ✓ (2)
- 4.2 4.2.1 Filler wire/wire. ✓ This wire melts to form the joint between the two metals that you want to join. ✓ (2)
- 4.2.2 Shielding gas CO₂ ✓ (1)
- 4.2.3 The filler wires gets too short. ✓
Use anti-spatter or spatter release. ✓ (2)
- 4.2.4 MIG contact tip ✓ (1)
- 4.2.5
- Use a welding helmet. ✓
 - Protect your body by wearing a leather apron and gloves. ✓
- (2)
- 4.2.6 Electricity / CO₂ gas. ✓ (1)
- 4.3
- Requires a reduced melting pool, big enough to create the wanted penetration. ✓
 - Done by reducing the size of the flame. ✓
 - Force of the flame will help to keep the molten metal positioned. ✓
- (3)

- 4.4 4.4.1 a) Longitudinal shrinking ✓
 b) Angular shrinking longitudinally ✓
 c) Angular shrinking ✓
 d) Lateral shrinking ✓ (4)

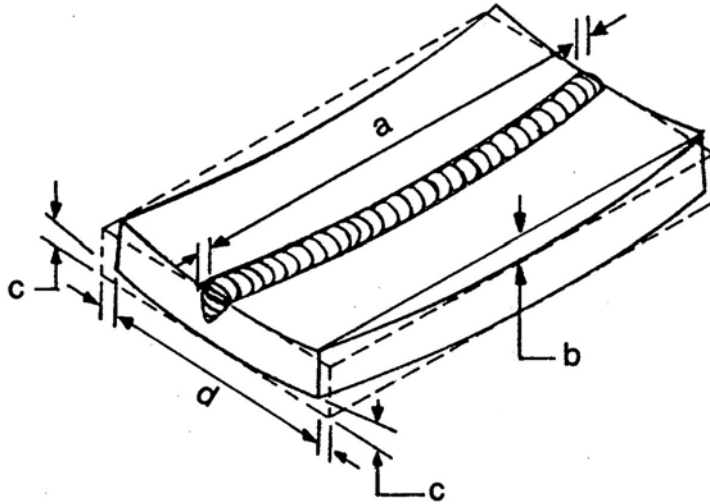

- 4.4.2 • Clamping ✓
 • Patch work ✓
 • Make use of short welding runs. (Any two) (2)

- 4.4.3 • Heating to an acceptable temper temperature. ✓
 • Cooling at a controlled temperature. ✓ (2)

- 4.5 • See that the surface is clean and slightly warm. ✓
 • Apply a layer of polish. ✓
 • Allow it to dry and rub in. ✓ (3)
[35]

QUESTION 5: TOOLS, IMPLEMENTS AND EQUIPMENT

- 5.1 5.1.1
- Connected to the three-point mechanism of the tractor. ✓
 - Top link. ✓
 - Connect to the PTO shaft .
- (3)
- 5.1.2 PTO / Power take-off ✓ (1)
- 5.1.3 Levelling box. ✓ (1)
- 5.1.4
- Must appear neat. ✓
 - Safeguard the equipment. ✓
 - Removed and replaced easily. ✓
 - Do not become loose easily.
 - Weight saving.
 - Keep out all undesired matter.
- (3) (any three)
- 5.2 5.2.1 Thermo siphon cooling system. ✓ (1)
- 5.2.2
- A Radiator ✓
 - B Fan ✓
 - C Water jacket ✓
 - D Connecting rubber hose ✓
- (4)
- 5.2.3
- It is based on the principle of circulating water in the cooling system through the rise of heat. ✓
 - The water surrounding the cylinders of the engine, heats up ✓ and then flows upward to the highest point in the engine block where it exits to enter the radiator through the upper radiator hose into the header tank. ✓
- (3)
- 5.2.4
- Perished rubber seal ✓
 - Tension spring that loses its tension ✓
 - Water pressure too high inside engine. (overheats) (any two)
 - Because of a loose cap.
- (2)

- 5.3 5.3.1 A Helical gear ✓
B Straight cut gear ✓ (2)

5.3.2

	HELICAL GEAR	STRAIGHT CUT GEAR
APPLICATION	Gearbox✓ Differential	Final drive✓ Gear box
ADVANTAGE	Lasts a long time. ✓	Can be meshed from the side. ✓ No side thrust.
DISADVANTAGE	Subjected to side thrust under load. ✓	Noisy. ✓

(6)

- 5.3.3 Cast iron ✓ (1)

- 5.3.4 Low viscosity oil ✓ (1)

- 5.4 5.4.1 A is the better one because:✓
 - The tension on the clutch plate can be changed. ✓
 - A has a universal joint for angular movement. ✓
(3)

- 5.4.2 Dismantle the slip clutch, clean it ✓and reassemble it but do not put the springs under tension. ✓ (2)

- 5.4.3 Point on the machine where different parts come into contact that causes friction where you must apply lubrication in the form of grease with a grease gun. ✓ (1)

- 5.5
- Cut steel, concrete ✓
 - Grinding
 - Finishing off
- (1)
(any one) **[35]**

QUESTION 6: WATER MANAGEMENT

- 6.1 6.1.1 A Electrical submersible pump. ✓
B Rotary pump. ✓ (2)
- 6.1.2
- Purpose of pump or purpose of use. ✓
 - Required delivery, quantity of water needed. ✓
 - Water quality has an affect on material of pump. ✓
 - Type of power source available. ✓
 - Mobility of pump to be used in different locations. ✓
 - Simplicity of design for easy/cheaper repairs.
 - Maintenance required.
 - Self installation. (any five) (5)
- 6.1.3
- If the motor is not 100% watertight it can be damaged. ✓
 - The pump can only be driven by electricity. ✓ (2)
 - If the water level drops too low the pump unit can be damaged.
 - Plants roots or foreign objects can block valves and sieves. (any two)
- 6.1.4 Sieve or grid. ✓ (1)
- 6.2 6.2.1
- No labourers needed to shift the pipes/system. ✓
 - One-man operation. ✓
 - Automated watering system/scheduling.
 - Pesticides/fertilizers are applied through the system. (any two) (2)
- 6.2.2 So that the quantity of water that is administered to the crop can be equal ✓
✓from the centre of the land to the outer edge. ✓ (2)
- 6.2.3 Inner nozzles smaller ✓ and further apart than outer nozzles. ✓ (2)
- 6.2.4
- Fertilisers with a high acid content. ✓
Acid will corrode the galvanized pipes ✓
 - Fertilisers with a large particle size. ✓
Large particles will block the nozzles ✓ (4)
- 6.2.5 Cell phone /two way radio /computer ✓ (1)
- 6.2.6
- Bury deep enough ✓ so that implements cannot damage it. ✓
 - Bury in sand ✓ so that it can be repaired easily. ✓
 - Apply thin layer of lime ✓ just above the pipe to serve as an indicator to the operator of the machines that he is near the pipe. ✓
 - Draw a map of the exact position of the pipeline. (6)
- (3 x 2)

6.3	6.3.1	Automatic water supplier/Pipe with small holes. ✓	(1)
	6.3.2	<ul style="list-style-type: none">• Pressure high enough to satisfy needs. ✓• Prevent spillage. ✓• Joints must be watertight.• Removal of spillage water.• Protection of all the valves.• Placing of troughs.	(2)
		(any two)	[30]
		TOTAL SECTION B:	155
		GRAND TOTAL:	200