



education

Department:
Education
REPUBLIC OF SOUTH AFRICA

**NATIONAL
SENIOR CERTIFICATE**

GRADE 12

ELECTRICAL TECHNOLOGY

NOVEMBER 2008

MARKS: 200

TIME: 3 hours

This question paper consists of 11 pages and a formula sheet.



INSTRUCTIONS AND INFORMATION

1. Answer ALL the questions.
2. Sketches and diagrams must be large, neat and fully labelled.
3. ALL calculations must be shown, and should be rounded off correctly to TWO decimal places.
4. Number the answers correctly according to the numbering system used in this question paper.
5. A formula sheet is attached at the end of the question paper.
6. Non-programmable calculators may be used.



QUESTION 1: TECHNOLOGY, SOCIETY AND THE ENVIRONMENT

- 1.1 Technology is developed by people for people. At the very foundation of this action are entrepreneurs. Entrepreneurs are the people who can identify possibilities and who are willing to take financial risks in order to establish technological enterprises.

Describe FOUR basic principles entrepreneurs could follow when establishing a technological enterprise. (4)

- 1.2 People use technologies and systems to meet their needs and desires. The use of technology has positive and negative impacts on society and the environment. Discuss briefly how the use of technologies can impact negatively on the following:

- 1.2.1 Land (2)
1.2.2 Water (2)
1.2.3 Air (2)
[10]

QUESTION 2: THE TECHNOLOGICAL PROCESS

- 2.1 On reaching old age, some elderly people find it very difficult, and often frightening, to climb up and down stairs. Common possible solutions might be to live downstairs, to make renovations to the house, or maybe to move into an old-age home. Mrs Sebola did not want to accept any of the possible solutions. She wanted to continue to live as she has always lived. Mrs Sebola has contracted you to design the electrical system which will control a chair-type device that will transport her up and down the stairs.

Describe FIVE specifications the electrical system of the chair-lift will have to adhere to. (5)

- 2.2 During the year you were required to complete a practical assessment task (PAT). As part of this process you were required to complete a number of steps. These steps included the following:

1. Critical evaluation of a scenario and the identification of a problem
2. Identification of a solution to the problem
3. Research of possible solutions to the problem and decide on a design
4. Conduct simulations
5. Build a prototype/artefact

Describe in your own words the intention or significance of each step listed above. (5)
[10]



QUESTION 3: OCCUPATIONAL HEALTH AND SAFETY

- 3.1 State ONE unsafe act that could take place in an electrical technology workshop. (1)
- 3.2 State ONE unsafe condition that could exist in an electrical technology workshop. (1)
- 3.3 State FOUR steps that must be adhered to, in order of priority, when discovering a person who has become a victim of an electrical shock in a workshop. (4)
- 3.4 Describe TWO good housekeeping rules that will ensure that the electrical technology workshop is a safe place to work in. (4)
- [10]**

QUESTION 4: THREE-PHASE AC GENERATION

- 4.1 Name ONE method that can be used to improve the cost effectiveness of an induction motor operating with a poor lagging power factor. (1)
- 4.2 Draw a neatly labelled phasor diagram of a balanced three-phase system. (4)
- 4.3 A three-phase star-connected induction motor draws a current of 8 A when connected to a 415 V/50 Hz supply. If the motor has a power factor of 0,85 determine the following:
- 4.3.1 The current in each phase of the motor winding (2)
- 4.3.2 The voltage across each phase (3)
- [10]**



QUESTION 5: R, L AND C CIRCUITS

5.1 The circuit shown in FIGURE 5.1 is at resonance. Explain how an increase in frequency will impact on the following voltages: V_1 , V_2 and V_3 as well as on the current. Give reasons for your answers.

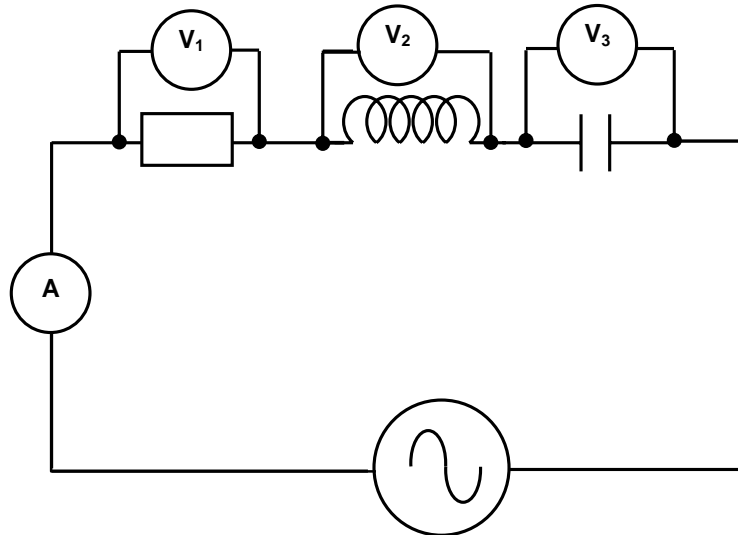

FIGURE 5.1 – RLC SERIES CIRCUIT

(8)

5.2 A RLC parallel circuit is connected as shown in FIGURE 5.2.

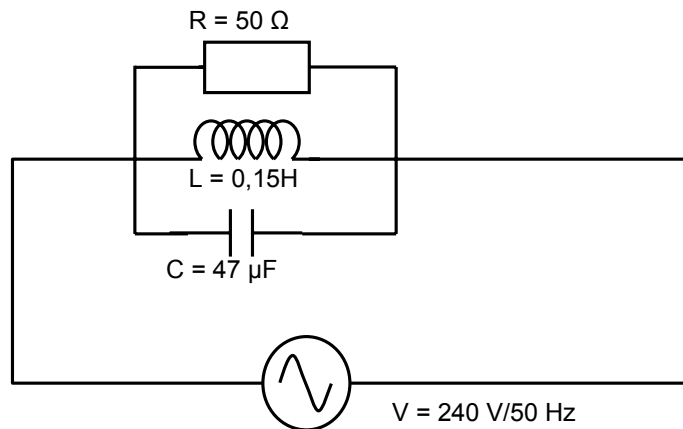

FIGURE 5.2 – RLC PARALLEL CIRCUIT

Calculate the following:

5.2.1 The current flow through each branch (9)

5.2.2 The total current flow through the circuit (3)

5.3 Draw a neatly labelled phasor diagram representing the circuit in FIGURE 5.2. (7)



5.4 Calculate the current flowing in the circuit shown in FIGURE 5.3.

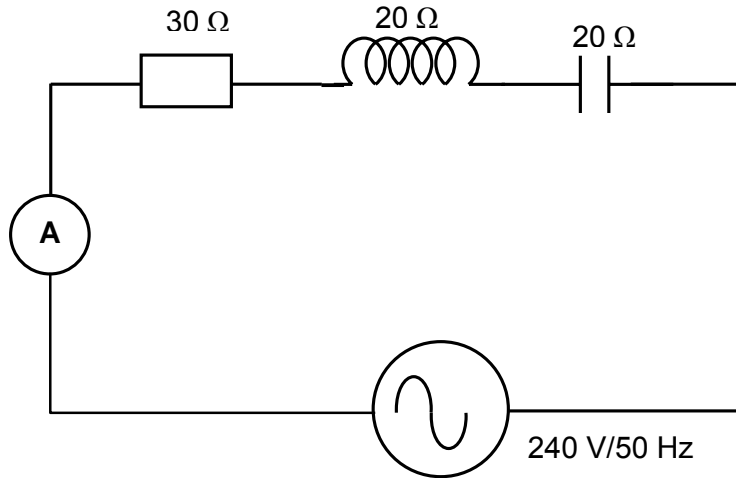

FIGURE 5.3 – RLC SERIES CIRCUIT

(3)
[30]

QUESTION 6: SWITCHING AND CONTROL CIRCUITS

6.1 The circuit diagram shown in FIGURE 6.1 makes use of an SCR to control the brightness of a lamp. The circuit is connected to 240 V/50 Hz mains supply. Explain the basic principle of the operation of the circuit.

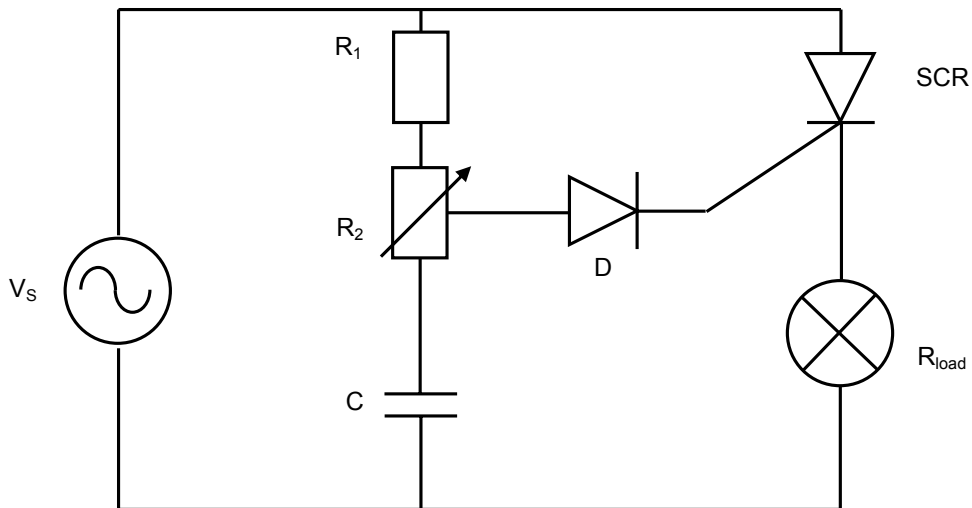

FIGURE 6.1 – SCR LAMP DIMMING CIRCUIT

(10)

6.2 How is a TRIAC switched on?

(5)

6.3 How is a TRIAC switched off?

(2)

6.4 State THREE advantages that a TRIAC has over that of a SCR.

(3)



6.5 Draw and label the following symbols:

6.5.1 TRIAC (3)

6.5.2 DIAC (2)

[25]

QUESTION 7: AMPLIFIERS

7.1 Name FOUR characteristics of an ideal operational amplifier. (4)

7.2 The circuit shown in FIGURE 7.1 must switch between a gain of 10 and 90. Calculate the values of R_{F1} and R_{F2} that must be used.

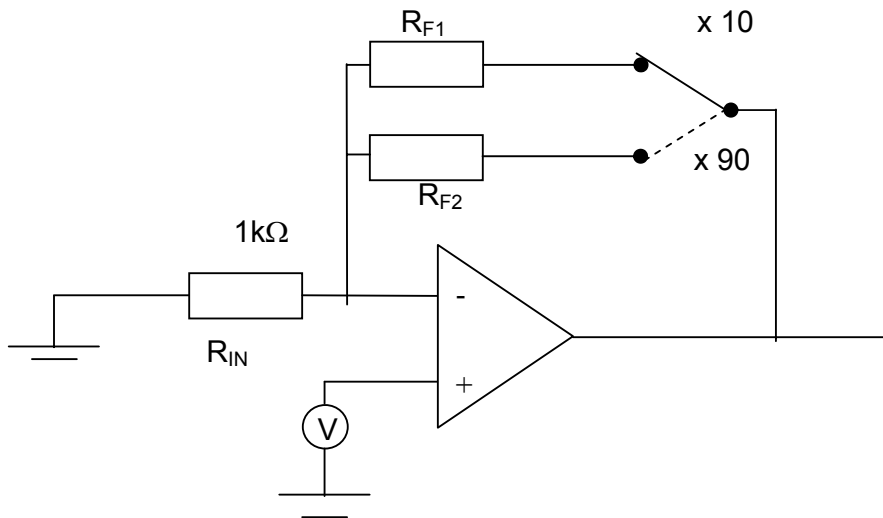

FIGURE 7.1 – OPERATIONAL AMPLIFIER CIRCUIT (8)

7.3 Calculate the gain of the following amplifier shown in FIGURE 7.2.

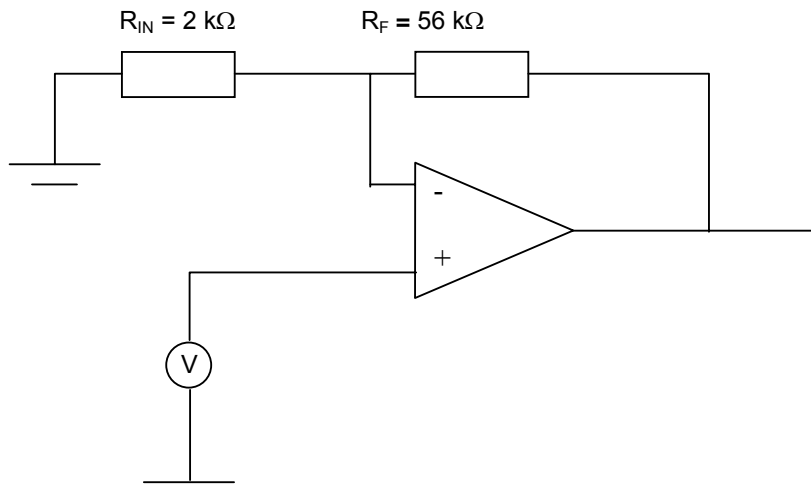

FIGURE 7.2 – NON-INVERTING AMPLIFIER CIRCUIT (3)



7.4 Determine the output voltage (V_{out}) of the voltage comparator shown in FIGURE 7.3 with the following input:

7.4.1 $V_1 = 6\text{ V}$ and $V_2 = 5\text{ V}$ (1)

7.4.2 $V_1 = 5\text{ V}$ and $V_2 = 5\text{ V}$ (1)

7.4.3 $V_1 = 4\text{ V}$ and $V_2 = 8\text{ V}$ (1)

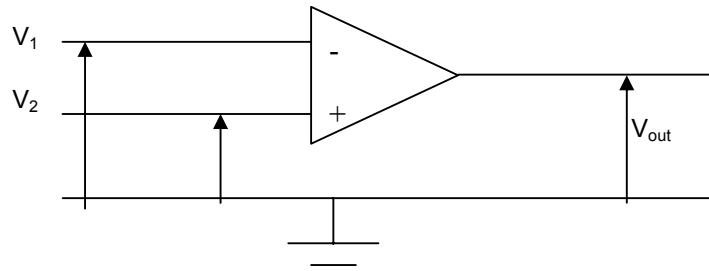

FIGURE 7.3 – VOLTAGE COMPARATOR

7.5 Identify the circuit shown in FIGURE 7.4. Draw TWO labelled cycles of the input and output wave forms on one graph.

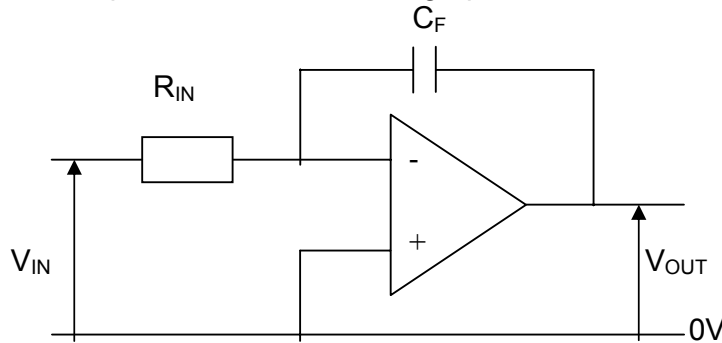

FIGURE 7.4 – OPERATIONAL AMPLIFIER CIRCUIT

(7)
[25]

QUESTION 8: THREE-PHASE TRANSFORMERS

8.1 There are various methods of connecting the primary and the secondary windings of three-phase transformers. State TWO methods. (2)

8.2 A transformer used to supply a farm gets very hot, which is unacceptable and has to be switched off in order to cool down.

8.2.1 State TWO causes of overheating in transformers. (2)

8.2.2 Explain how overheating in transformers can be prevented. State TWO methods. (2)



8.3 A 24 kVA transformer supplies power to a football stadium that is being erected for the 2010 FIFA Soccer World Cup. The transformer supplies the stadium with an output line voltage of 415 V when it is connected in delta-star. The input voltage to the transformer is 11 000 V.

Calculate the following:

8.3.1 The phase voltage supplied to the stadium (3)

8.3.2 The maximum line current that can be drawn from the supply (the primary current) (3)

8.3.3 The maximum power that can be delivered at full load if the power factor is lagging at 0,85 (3)
[15]

QUESTION 9: LOGIC CONCEPTS AND PLCs

9.1 Consider the following scenario and solve the problem stated using LOGIC:

- A manufacturing plant uses two tanks to store a liquid chemical.
- Each tank has a sensor that detects when the liquid chemical level drops to 75% full.
- The sensors produce a 5-volt signal at a level of 75% full (logic 1).
- The sensors produce a 0-volt signal at a level of 25% full (logic 0).
- It is required that a single green lamp on an indicator panel lights up when both tanks are above 25% full.

Show how a NAND gate can be used to implement the functions above. A logic 1 (5 V) is required to switch on the green light. (5)

9.2 A network of cascade inverters is shown in FIGURE 9.1. If a HIGH (logic 1) is applied to point A, determine the logic levels at the points labelled B through to F.

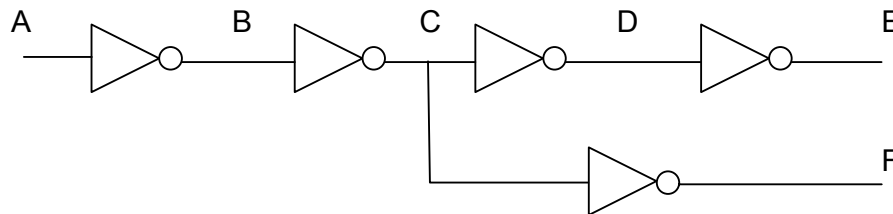

FIGURE 9.1 – CASCADE INVERTERS (5)



9.3 Identify and draw the truth table of the logic symbol shown in FIGURE 9.2.

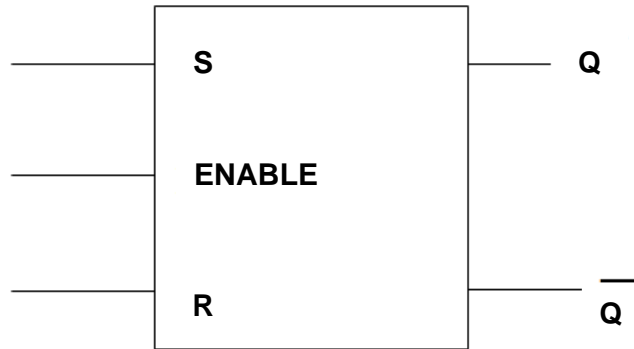

FIGURE 9.2 – BLOCK DIAGRAM OF A LOGIC LATCH

(4)

9.4 Apply De Morgan's theorem to the following Boolean expression:

$$Z = \overline{ABC + DEF}$$

(4)

9.5 Give the Boolean expression of the ladder diagram shown in FIGURE 9.3.

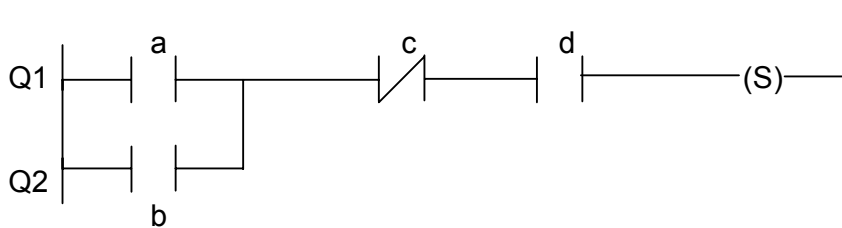

FIGURE 9.3 – PLC LADDER DIAGRAM

(5)

9.6 Draw the ladder logic diagram of the following direct-on-line-starter shown in FIGURE 9.4.

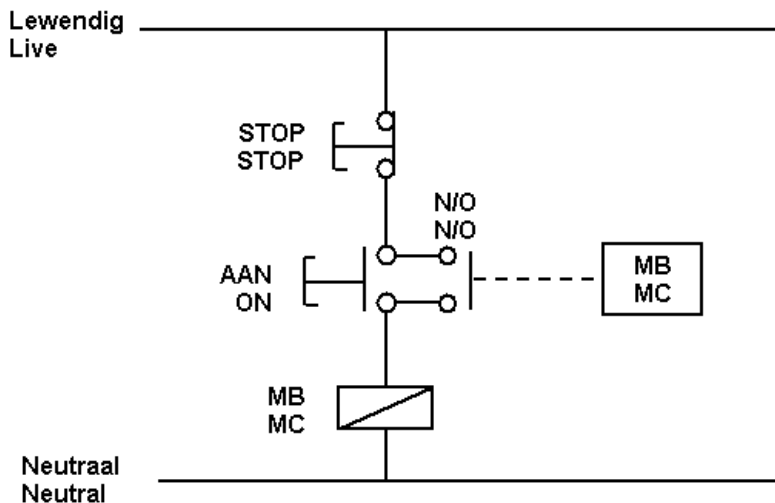

FIGURE 9.4 – DIRECT-ON-LINE-STARTER

(7)

9.7 State FIVE advantages of programmable logic controllers (PLCs).

(5)

[35]



QUESTION 10: THREE-PHASE MOTORS AND CONTROL

- 10.1 Answer the following questions with reference to star-delta starters.
- 10.1.1 Why are star-delta starters used to start three-phase motors? (2)
- 10.1.2 Briefly explain the *star-delta starting process*. (6)
- 10.2 What action does a forward-reverse three-phase starter need to change the direction of a three-phase motor? (2)
- 10.3 Explain the term *normally-open contacts*, with reference to motor starters. (2)
- 10.4 Explain the function of an *overload unit* in a motor starter. (3)
- 10.5 Electrical motors have internal losses. Name and describe ONE of the losses. (3)
- 10.6 Explain the basic principle of operation of a three-phase squirrel-cage induction motor. (7)
- 10.7 Before a motor is started, after it has been installed, basic mechanical and electrical inspections should take place. Name TWO basic mechanical and THREE basic electrical inspections that must take place before the commissioning of the motor. (5)
- [30]**
- TOTAL: 200**



FORMULA SHEET

$$X_L = 2\pi FL$$

$$X_C = \frac{1}{2\pi FC}$$

$$Z = \sqrt{R^2 + (X_L - X_C)^2}$$

$$I_T = \sqrt{I_R^2 + (I_C - I_L)^2}$$

$$V_T = \sqrt{V_R^2 + (V_C - V_L)^2}$$

$$f_r = \frac{1}{2\pi\sqrt{LC}}$$

$$Q = \frac{1}{R}\sqrt{\frac{L}{C}}$$

$$Q = \frac{X_L}{R} = \frac{V_L}{V_R}$$

$$\cos\theta = \frac{I_R}{I_T}$$

$$\cos\theta = \frac{R}{Z}$$

$$\left. \begin{array}{l} P = VI \cos\theta \\ S = VI \\ Q = VI \sin\theta \end{array} \right\} \text{Single phase}$$

$$\left. \begin{array}{l} P = \sqrt{3} V_L I_L \cos\theta \\ S = \sqrt{3} V_L I_L \\ Q = \sqrt{3} V_L I_L \sin\theta \end{array} \right\} \text{Three phase}$$

$$\left. \begin{array}{l} V_L = V_{Ph} \\ I_L = \sqrt{3} I_{PH} \end{array} \right\} \text{Delta}$$

$$\left. \begin{array}{l} V_L = \sqrt{3} V_{Ph} \\ I_L = I_{Ph} \end{array} \right\} \text{Star}$$

$$f = \frac{1}{T}$$

$$A_v = \frac{R_f}{R_m} + 1$$

$$\frac{V_1}{V_2} = \frac{N_1}{N_2} = \frac{I_2}{I_1}$$

$$\eta = \frac{P_o}{P_i}$$

$$\beta = \frac{I_c}{I_b}$$

$$I_b = I_e - I_c$$

$$P_G = 10 \log \frac{P_o}{P_i}$$

